

Quick Start Guide

Version 1.1
Date 15/12/2023

PIXIE

PIXIE Signal Booster G3

SGB3BTAS

1. Foreword

IMPORTANT: IN THE INTEREST OF PRODUCT PERFORMANCE AND SAFETY PLEASE READ THESE GUIDE AND WARRANTY INSTRUCTIONS BEFORE INSTALLING THE PRODUCT.



SAL products are designed in accordance with all mandatory International and Australian Standards, which require installation in accordance with AS/NZS3000 by a qualified installer and regular cleaning and maintenance of the equipment. Products are sold in accordance with the following instructions and SAL standard terms and conditions of sale, available via www.sal.net.au.

Due to continued product and information updates, product data sourced from sal.net.au shall not form part of any contract and or technical performance guarantee unless expressly confirmed in writing by SAL at the time of order. The product wireframe drawings in this document are intended for illustration purposes only and may differ from the final physical product. The installation instruction is subject to change without prior notice.

2. Product Introduction

PIXIE Signal Booster G3 is the 3rd generation Bluetooth Mesh signal booster, designed to expand the signal coverage of an established PIXIE network, expanding the control distances and enhancing PIXIE local wireless communication stability where signal strength is less than ideal due to building materials, architecture and product placement.

2.1 Product Features

- Significantly expands signal coverage, enhancing PIXIE wireless control stability
- Sleek design, suitable for mounting in different locations
- In-built single button for easy, simplified setup
- In-built single LED indicator for easy operational status indication.

2.2 The package includes

- PIXIE Signal Booster G3 * 1
- Quick Start Guide * 1

*All drawings shown are for illustration purpose only, actual product may vary due to product enhancement.

2.3 Product illustration*

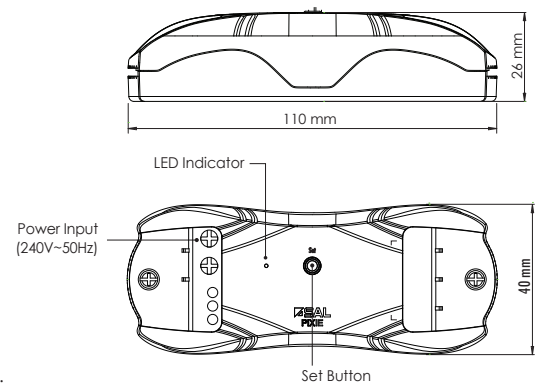

3. Specifications

Model NO.	SGB3BTAS	Input	240V~ 50Hz
Product Application	Residential, Commercial	Output	Wireless signal
Operation Ambience Temperature (°C)	0 ~ 40	IP Rating	IP20
Storage Ambience Temperature (°C)	0 ~ 60	Operation Humidity	10% - 85% RH, NC
Storage Humidity	10% - 85% RH, NC	Role in PIXIE System	Secondary

4. Installation and Wiring

4.1 Preparation

-Make sure there is a PIXIE network (namely "HOME" in the App) created

-Select a location for installation, typically a signal blackspot, e.g. centrally between two PIXIE devices with a distance of over 15 meters (open space), or where solid obstacles like brick walls, concrete walls, glass doors are present between PIXIE devices

4.2 Installation**

1. Disconnect the power supply, mount this device onto desired location
2. Wire the PIXIE Signal Booster G3 as per the wiring diagram on the right
3. Supply power to the PIXIE Signal Booster G3, make sure the LED indicator is lit and in white colour
4. Add this device into the PIXIE network (via the App or a PIXIE master device), when the LED indicator turns solid blue, it's all set

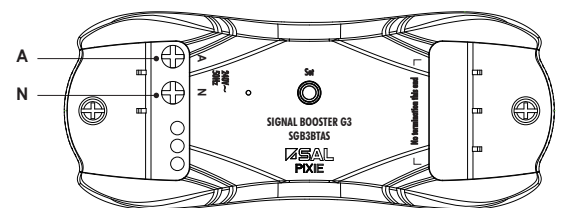

Wiring diagram

** This product must be installed by a licensed electrician.

5. Operation

5.1 How to add a PIXIE Signal Booster G3 into a network

Option 1 - Use PIXIE/PIXIE PLUS App on the phone

Use the "Add device" function to search for the PIXIE Signal Booster G3, when it's shown as available in the App, tap "Add" button to finalise the adding process. When the LED indicator changes from white to solid blue, the adding process is successful

Option 2 - Use physical button

Find any PIXIE master device with a physical button in the desired network, (e.g. a PIXIE smart switch/dimmer), quickly click its button 4 times to enter pairing mode. Then, quickly click the button of PIXIE Signal Booster G3 4 times within 30 seconds. When the LED indicator changes from white to solid blue, the pairing process is successful, and the PIXIE Signal Booster G3 is added to the same PIXIE network of the PIXIE master device.

5.2 Button operation

4 clicks: The device enters pairing mode (for adding this device into a PIXIE network), the LED indicator will quickly flash in blue for 10 seconds.

9 clicks: Reset the device to factory default. The LED indicator flashes in blue and white for 3 seconds then stay at white

5.3 The LED indicator

- The LED indicator is solid white colour when the device is new or factory reset
- The LED indicator is solid blue colour when it's added into a PIXIE network

6. How to download App

Scan QR code or go to App store (IOS) or Google Play (Android) to download the free PIXIE app to your smart phone.

IOS: Requires IOS 6.0 or later. Compatible with iPhone, iPad and iPod touch

Android: Requires Android 4.4 or above, devices must support Bluetooth 4.0

Specifications above are for reference only and may vary without prior notice.



7. Warranty

In accordance with SAL's standard terms and conditions of sale, SAL warrant this product to be free from defects in materials and or workmanship for a period as stated below for goods not subject to incorrect installation, maintenance, operation, mishandling, environmental, unauthorised modifications or electrical operating conditions outside the nominated product specification as detailed in these installation instructions.

The benefits to you given by this warranty are in addition to other rights and remedies you have under law. Our goods come with guarantees that cannot be excluded under the Australian Consumer Law. You are entitled to a replacement or refund for a major failure and compensation for any other reasonably foreseeable loss or damage. You are also entitled to have the goods repaired or replaced if the goods fail to be of acceptable quality and the failure does not amount to a major failure.

Warranty term – Residential usage (12) months, Commercial usage (12) months

7.1 How to make a claim?

Step #1 – Within 30 days of the fault discovery, please contact the original place of the SAL product purchase during standard (local) business hours, with the following information (a) proof of purchase (b) description and quantity of the claimed fault (c) address of installation. (d) operating hours of the product.

Step #2 – It is then the responsibility of the original place of product purchase to report the matter to SAL aftersales;

NSW ACT	SAL National Pty Ltd, 40 Biloela Street Villawood NSW 2163	P # 02 9723 3099
QLD	SAL National Pty Ltd, 36 Whitelaw Place Richlands QLD 4077	P # 07 3879 5999
VICT TAS SA NT	SAL National Pty Ltd, 46-48 Keys Road Moorabbin Victoria 3189	P # 03 9532 3168
WA	SAL National Pty Ltd, 29 Beringarra Av Malaga WA 6090	P # 08 9248 7458

Step #3 - Upon review of your claim and if the product is required to be returned to SAL for technical evaluation, then at the owners expense the product must be returned to SAL as per the above nominated locations.

Step #4 - Pending the evaluation, the claim will be validated resulting in the product being repaired or replaced with the same or best equivalent product at the discretion of SAL, or rejected if the product fault was found to be caused by conditions beyond the responsibility of SAL warranty obligations. Consideration of installation, product removal, return freight and or testing fees are not the responsibility of SAL.

8. Scan QR code to access the full product information

