

## PIXIE Smart Dimmer G3

#SDD300BTAM



### ▶ Basic operation

- 1 click operate lights on/off
- To dim, long press and hold.
- 2 clicks go to maximum output
- 4 clicks manual pairing
- 5 clicks locks minimum dim
- 7 clicks reset minimum level
- 9 clicks reset device

### ▶ Applications

Residential dwellings for retrofit, renovation and new build; apartments; hotels and hospitality venues.

### ▶ Whats in the box

1 x Smart dimmer, 1 x silicone adaptor/spacer, 3 x switch caps, 1 x capacitor, installation instructions

### ▶ Accessories

PIXIE Ambience wall and faceplates in White/Grey/Black



SCAN ME

Download the PIXIE and  
PIXIE PLUS Apps



#SDD300BTAM  
PIXIE Smart Dimmer G3



PIXIE Generation 3 (G3) digital push button smart dimmer for lighting control with wireless Bluetooth Mesh Technology in residential, hotel and hospitality spaces. Comes with 24hour/7 Day scheduling, Groups, Scenes, adjustable fade rates and mobile app control & configuration with ~30% improved Bluetooth signal strength over G2 PIXIE dimmer.

## Features

- Compact form factor allows for up to 6 Gang dimming wall plates
- Superb visual comfort with adjustable fade rates for scenes and schedules with soft start / stop as standard.
- Selectable LED indicator colour (Blue or Amber) and intensity (HighLight / LowLight) based on dimmer state.
- Suitable for dimming LED, tungsten, halogen light sources
- Fits most branded switch plates and PIXIE Ambience plates
- Smart functions and configuration via PIXIE or PIXIE Plus app
- Memory dimmer function returns to previous dimmed level from off
- Over temperature, overload, short circuit protection
- Backwards compatible with all PIXIE G1 and G2 PIXIE devices

## Electrical

Power Supply	220-240VAC
Min/ Max loads*	2W*/300W - 250VA LED
Dimming Method	Phase cut - Trailing edge
Operating ambient min/max (°C)	0 to 40°
Typical wireless range	15 metres typical indoors **
IP Rating	IP20

\*Subject to product capability, this size load may require the inclusion of the LOAD capacitor included in the product carton.  
\*\* Depending on building materials and construction.



## PIXIE Smart Dimmer

#SDD300BTAM G3



### Related products

PIXIE 600W Switch  
#SWL600BTAM



PIXIE Multifunction  
#SMFBTAS



PIXIE Smart Dimmer  
SDD350BT



PIXIE Timer Switch  
#STS350BT



## Wiring Diagram

SDD300BTAM - Standard wiring diagram

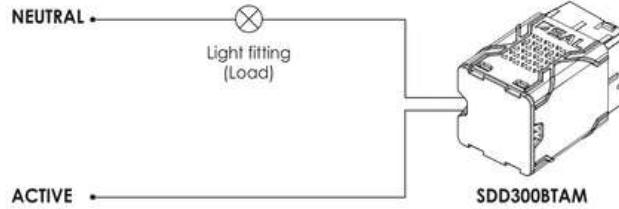

SDD300BTAM - Optional wiring diagram

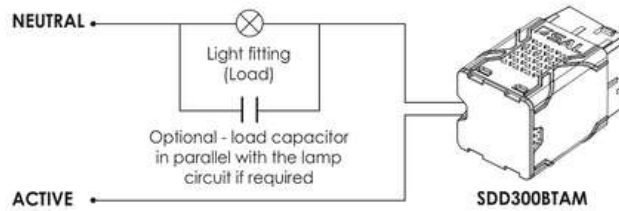

## Derating Recommendations

### MULTI-GANG DE-RATING (Maximum 6 x gang configuration)

No. of dimmer	Resistive load (Incandescent lamp, High voltage halogen lamp)	Capacitive load (Dimmable LED)
1	300W	250VA
2	250W	200VA
3	200W	150VA
4	150W	150VA
5	100W	100VA
6	75W	75VA

## PIXIE fits in

PIXIE fits in to a huge range of Australian wall plates



SCAN ME



SCAN ME

Download the PIXIE and  
PIXIE PLUS Apps



## PIXIE Smart Dimmer G3

#SDD300BTAM/BP

 **Bluetooth**

### ▶ Basic operation

- 1 click operate lights on/off
- To dim, long press and hold.
- 2 clicks go to maximum output
- 4 clicks manual pairing
- 5 clicks locks minimum dim
- 7 clicks reset minimum level
- 9 clicks reset device

### ▶ Applications

Can be used as an in-wall PUCK for use with custom or unusual wall plates - Other functions as per standard SDD300BTAM

### ▶ Whats in the box

1 x Smart dimmer, 1 x silicone adaptor/spacer, 3 x switch caps, 1 x capacitor, installation instructions

### ▶ Accessories

2 extra white cables for Bell Press / momentary press mech connections



SCAN ME

Download the PIXIE and  
PIXIE PLUS Apps



#SDD300BTAM/BP  
PIXIE Smart Dimmer G3



PIXIE Generation 3 (G3) digital push button smart dimmer for lighting control with wireless Bluetooth Mesh Technology in residential, hotel and hospitality spaces. Comes with 24hour/7 Day scheduling, Groups, Scenes, adjustable fade rates and mobile app control & configuration with ~30% improved Bluetooth signal strength over G2 PIXIE dimmer.

## Features

- PUCK Function - Comes with two extra wires (white) available for optional bell press (momentary switch) connection.
- Compact form factor allows for up to 6 Gang dimming wall plates
- Superb visual comfort with adjustable fade rates for scenes and schedules with soft start / stop as standard.
- Selectable LED indicator colour (Blue or Amber) and intensity (HighLight / LowLight) based on dimmer state.
- Suitable for dimming LED, tungsten, halogen light sources
- Fits most branded switch plates and PIXIE Ambience plates
- Smart functions and configuration via PIXIE or PIXIE Plus app
- Memory dimmer function returns to previous dimmed level from off
- Over temperature, overload, short circuit protection
- Backwards compatible with all PIXIE G1 and G2 PIXIE devices

## Electrical

Power Supply	220-240VAC
Min/ Max loads*	2W*/300W - 250VA LED
Dimming Method	Phase cut - Trailing edge
Operating ambient min/max (°C)	0 to 40°
Typical wireless range	15 metres typical indoors **
IP Rating	IP20

\*Subject to product capability, this size load may require the inclusion of the LOAD capacitor included in the product carton.  
\*\* Depending on building materials and construction.



## PIXIE Smart Dimmer

#SDD300BTAM/BP  
G3



### Related products

PIXIE 600W Switch  
#SWL600BTAM



PIXIE Multifunction  
#SMFBTAS



PIXIE Smart Dimmer  
SDD350BT



PIXIE Timer Switch  
#STS350BT



## Wiring Diagram

SDD300BTAM/BP - Standard wiring diagram

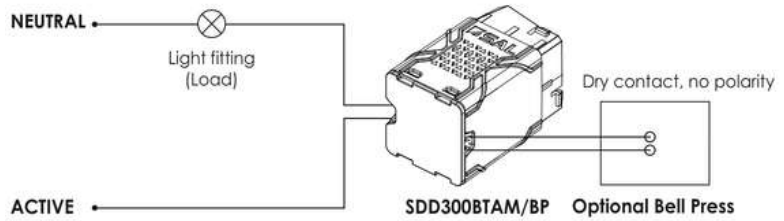

SDD300BTAM/BP - Optional wiring diagram

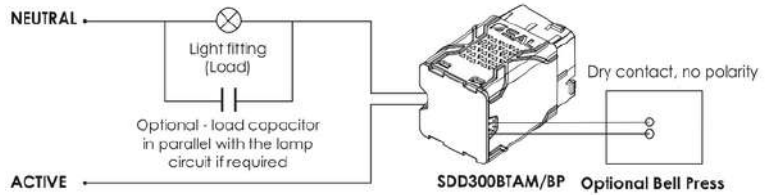

## Derating Recommendations

### MULTI-GANG DE-RATING (Maximum 6 x gang configuration)

No. of dimmer	Resistive load (Incandescent lamp, High voltage halogen lamp)	Capacitive load (Dimmable LED)
1	300W	250VA
2	250W	200VA
3	200W	150VA
4	150W	150VA
5	100W	100VA
6	75W	75VA

## PIXIE fits in

PIXIE fits in to a huge range of Australian wall plates



SCAN ME



SCAN ME

Download the PIXIE and  
PIXIE PLUS Apps



## PIXIE Smart Switch 600W

#SWL600BTAM



### ▶ Basic operation

- 1 click operate lights on/off
- 4 clicks manual pairing
- 9 clicks reset device

### ▶ Applications

Residential dwellings for retrofit, renovation and new build; apartments; hotels and hospitality venues.

### ▶ Whats in the box

1 x Smart switch, 1 x silicone adaptor/spacer, 3 x switch caps, 1 x capacitor, installation instructions

### ▶ Accessories

PIXIE Ambience wall and faceplates in White/Grey/Black



SCAN ME

Download the PIXIE and PIXIE PLUS Apps



#SWL600BTAM  
PIXIE Smart Switch 600W



Push button smart switch for controlling lighting and other loads with wireless Bluetooth Mesh Technology in residential, hotel and hospitality spaces. Comes with 24hour/7 Day scheduling, Groups, Scenes and mobile app control and configuration.

## Features

- Suitable for switching lighting and other compatible loads
- Loads greater than 600w control possible via contactor (by others).
- Fit most branded switch plates and PIXIE Ambience plates
- Smart functions and configuration via phone/tablet with PIXIE Apps
- Over temperature protection, overload protection, short circuit protection
- Complies with Australian and New Zealand: AS/NZS 60669.2.1
- LED indicator shines bright when the dimmer is on, and faint when the dimmer is off for locating in the dark
- LED indicator can be enabled and disabled through the PIXIE or PIXIE Plus app, when disabled, the indicator is off at OFF state, and lit at ON state

## Electrical

Power Supply	220-240VAC
Min/ Max loads*	13W*/600W - 400W LED
Max inductive loads	120W
Operating ambient min/max (°C)	0 to 40°
Typical wireless range	15 metres typical indoors **
IP Rating	IP20



\*Subject to product capability, this size load may require the inclusion of the LOAD capacitor included in the product carton.  
\*\* Depending on building materials and construction.

## PIXIE Smart Switch 600w

#SWL600BTAM



### Related products

#### PIXIE Smart Dimmer SDD300BTAM



#### PIXIE Smart Dimmer SDD350BT



#### PIXIE Smart Timer #STS350BT



#### PIXIE Multifunction #SMFBTAS



## Wiring Diagram

SWL600BTAM - Standard wiring diagram

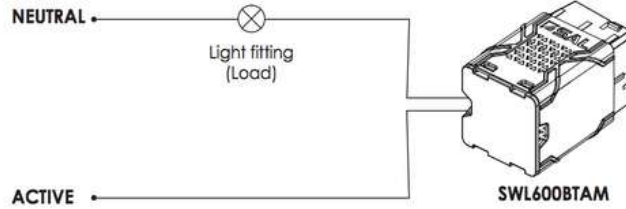

The SWL600BTAM is a 2 wire product, the capacitor provided in the carton operates as a load correction device to assist achieving minimum load levels and improve compatibility performances.

SWL600BTAM - Optional wiring diagram

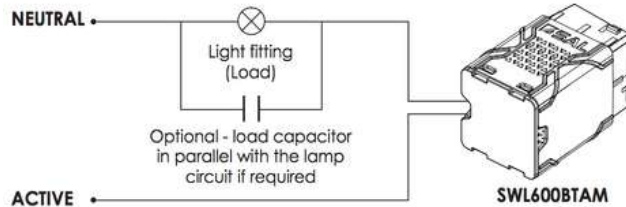

SWL600BTAM/BP - Bell Press

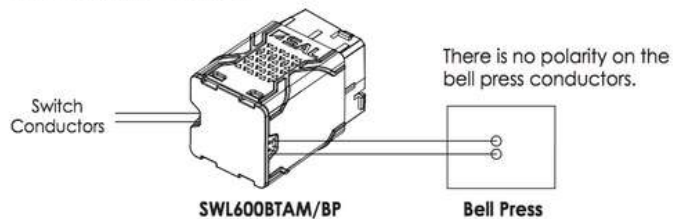

Optional BP ( Bell Press version - SWL600BTAM-BP ) accepts a bell press input from a bell-press mech or dry contact/volt free input from a 3rd party system to activate device. Bell press operation is identical to the button operation as described above.

## PIXIE fits in

PIXIE fits in to a huge range of Australian wall plates

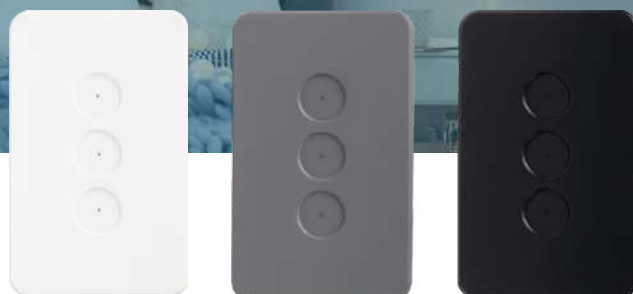

SCAN ME



SCAN ME

Download the PIXIE and  
PIXIE PLUS Apps



## PIXIE G3 Smart Timer Switch

#STS600BTAM



### ▶ Basic operation

- 1 click start /stop timer count down
- Long press for 2 seconds activate override-on mode
- 2 clicks when in timer mode, restart timer
- 4 clicks manual pairing
- 9 clicks reset device

### ▶ Applications

Bathroom and laundry exhausts fans, walk-in-robos, outdoor lighting and all delay-off applications

### ▶ Whats in the box

1 x Smart timer switch, 1 x silicone adaptor/spacer, 3 x switch caps, 1 x capacitor, installation instructions

### ▶ Accessories

PIXIE Ambience wall and faceplates in White/Grey/Black



SCAN ME

Download the PIXIE and PIXIE PLUS Apps

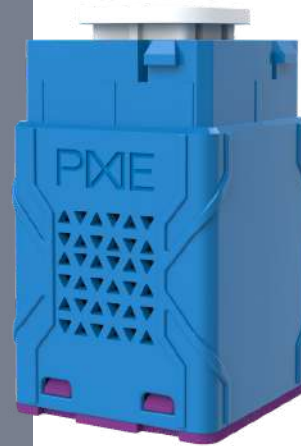

#STS600BTAM

PIXIE G3 Smart Timer Switch



Push button smart timer switch ideal for bathroom and laundry exhaust fan run-on timers. Also useful for walk-in-robos and anywhere an automatic delay-off function is needed. Duration from 1 minute to 24 hours and 24 hour/ 7 day scheduling built-in.

### Features

- Suitable for timing switched lighting and other compatible loads.
- Loads greater than 600W control possible via contactor (by others).
- Fit most branded switch plates up to 6 gangs and PIXIE Ambience plates
- Timer functions and configuration via phone/tablet with PIXIE Apps
- Timer operation LED indicator quickly flashes for 5 seconds on activation then flashes every 3 seconds
- Non timer operation LED indicator can be enabled and disabled through the PIXIE or PIXIE Plus app, when disabled, the indicator is off at OFF state, and lit at ON state

### Electrical

Power Supply	220-240VAC
Min/ Max loads*	13W*/600W - 400V AC LED
Max inductive loads	120V AC
Operating ambient min/max (°C)	0 to 40°
Typical wireless range	15 metres typical indoors **
IP Rating	IP20

\*Subject to product capability, this size load may require the inclusion of the LOAD capacitor included in the product carton.  
\*\* Depending on building materials and construction.



## PIXIE G3 Smart Timer Switch

#STS600BTAM



### Related products

PIXIE Smart Dimmer  
#SDD300BTAM



PIXIE Multiway  
#S2WBTAS



PIXIE 600W Switch  
#SWL600BTAM



PIXIE Multifunction  
#SMFBTAS



## Wiring Diagram

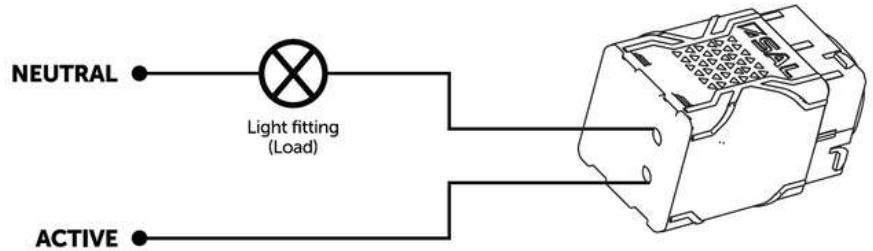

ALLOWABLE LOADS: INCANDESCENT & HALOGEN – 600W; LED – 400VA; FAN – 120VA

## Dimensions

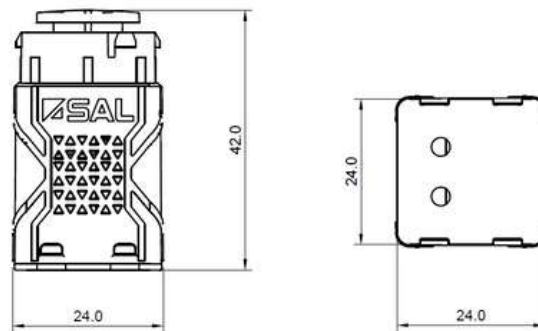

## PIXIE fits in

PIXIE fits in to a huge range of Australian wall plates



SCAN ME



SCAN ME

Download the PIXIE and  
PIXIE PLUS Apps





## PIXIE Multifunction Controller

#SMFBTAS



### ▶ Basic operation

- In Mimic mode, mimics button presses of Master devices
- In scene mode single click and / or double click recalls paired scene.
- 4 clicks manual pairing
- 5 clicks change LED colour
- 9 clicks reset device

### ▶ Applications

Perfect for 2-way, 3-way up to 8-way control of devices or groups. Welcome Home / Goodbye Scene recall etc.

### ▶ Whats in the box

1 x Multifunction controller, 1 x silicone adaptor/spacer, 3 x switch caps, installation instructions

### ▶ Accessories

PIXIE Ambience wall and faceplates in White/Grey/Black



SCAN ME

Download the PIXIE and  
PIXIE PLUS Apps



#SMFBTAS

PIXIE Multifunction Controller



Multifunction secondary devices which can be paired to operate with any Master PIXIE devices in either MIMC mode or SCENE mode. Control any PIXIE device, groups or scene from anywhere in the home with this device. Comes with Bluetooth Mesh Technology.

## Features

- Requires Active + Neutral connection from anywhere to operate
- Requires at least 1 PIXIE Master device to provide function
- Fit most branded switch plates and PIXIE Ambience plates
- Mimic Mode - mimc the control of any master device paired
- Scene Mode - single click and double click scene recall functions
- LED indicator can be changed colour (via the PIXIE Apps and button clicks) with choices between blue and orange for easier identification once installed
- Generation 3 product compatible with Gen 1 and Gen 2 products

## Electrical

Power Supply	220-240VAC
Min/ Max loads*	No connected load
Operating ambient min/max (°C)	0 to 40°
Typical wireless range	15 metres typical indoors **
IP Rating	IP20

\*Subject to product capability, this size load may require the inclusion of the LOAD capacitor included in the product carton.  
\*\* Depending on building materials and construction.



## PIXIE multi function controller

#SMFBTAS



### Related products

PIXIE Smart Dimmer  
#SDD300BTAM



PIXIE Smart Dimmer  
#SDD350BT



PIXIE Smart Timer  
#STS350BT



PIXIE 600W Switch  
#SWL600BTAM



## Wiring Diagram

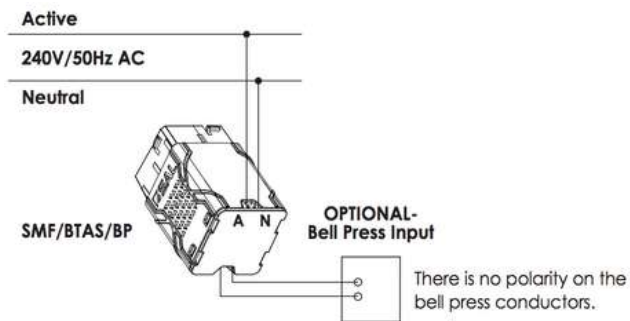
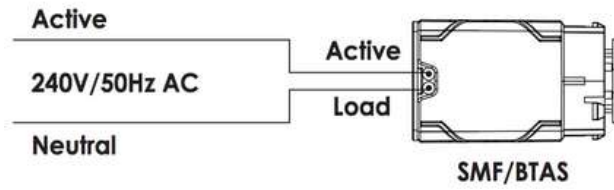

Optional BP ( Bell Press version - SMFBTAS-BP ) accepts a bell press input from a bell-press mech or dry contact/volt free input from a 3rd party system to activate device. Bell press operation is identical to the button operation as described above.

## PIXIE fits in

PIXIE fits in to a huge range of Australian wall plates



SCAN ME



SCAN ME

Download the PIXIE and  
PIXIE PLUS Apps



## PIXIE Multifunction Remote Control Mech

#SMRM/BTAS



### ▶ Basic operation

- In Mimic mode, mimics button presses of Master devices
- In scene mode single click and / or double click recalls paired scene.
- 4 clicks to pair device
- 9 clicks reset device

### ▶ Applications

Mobile, flexible controller for PIXIE home devices, groups & scenes. Ideal for locations where wiring is challenging

### ▶ Whats in the box

1 x Remote Multifunction remote mech, installation instructions

### ▶ Accessories

Australian sized wall plates for mounting and wall fixing.



SCAN ME

Download the PIXIE and PIXIE PLUS Apps

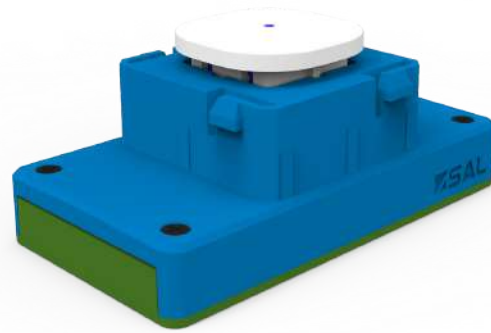

#SMRM/BTAS

PIXIE Multifunction Remote Control Mech



The PIXIE Multifunction Remote Control Mech is the 3rd generation multifunction remote control, that can be installed on switch plates to blend perfectly into the home environment. Without the need of running wires, this product brings huge flexibility for the application and installation.

## Features

- Coin battery powered, install anywhere without worrying wiring availability
- Designed for wall installation like normal Australian switch mechs, blends well with interior design.
- PIXIE Multifunction Remote Control Gen 3, can pair with a master device, a group or scenes
- LED indicator colour selectable - blue or amber
- Max. 3 gang installation
- Fit into most Australian switch plates

## Electrical

Power Supply	2 x CR2032 Battery
Operating ambient min/max (°C)	0 to 40°
Typical wireless range	15 metres typical indoors **
IP Rating	IP20
Dimensions	45(L) x 24.5(W) x 19(H)
Battery Type and quantity	2 x C2025

\*\* Depending on building materials and construction.



## PIXIE Multifunction Remote Control Mech

#SMRM/BTAS

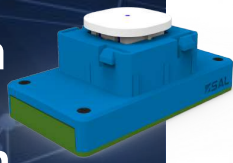

## Additional details

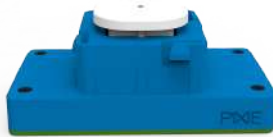

The perfect way to provide PIXIE control where running a wire is not possible and for remote control applications.

Each Multifunction remote Control Mech can be assigned a single-tap and / or double-tap function for fast access to devices, groups and scenes.

## Related products

PIXIE Smart Dimmer  
#SDD300BTAM



PIXIE 600W Switch  
#SWL600BTAM





PIXIE Multifunction  
#SMFBTAS

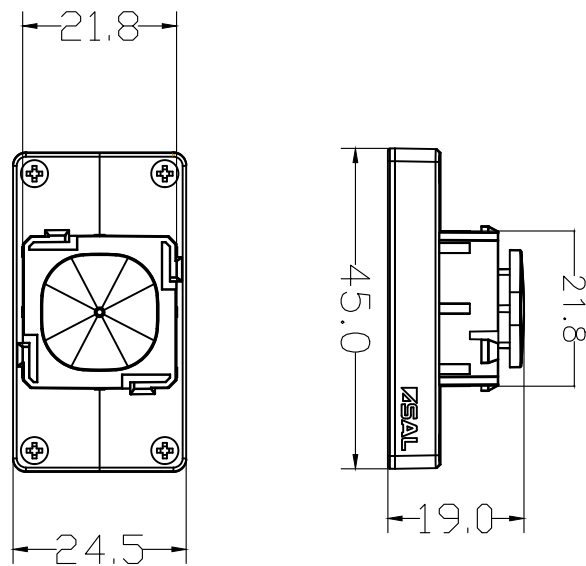

PIXIE Gateway G3  
#SGW3BTAM



 <b>WARNING</b>	
<p><b>KEEP OUT OF REACH OF CHILDREN</b> Swallowing can lead to chemical burns, perforation of soft tissue, and death. Severe burns can occur within 2 hours of ingestion. Seek medical attention immediately.</p>	

## PIXIE fits in

PIXIE fits in to a huge range of Australian wall plates



SCAN ME



SCAN ME

Download the PIXIE and  
PIXIE PLUS Apps



## PIXIE Multifunction Rotary Controller

#SMFR/BTAS  Bluetooth®

### ▶ Dial operation

- Multiple Operating Modes
- Paired with dimming products
- Paired with switching products
- Paired with scenes
- Paired with groups
- 4 clicks manual pairing
- 9 clicks reset device

Full operating detail provided in installation manual

### ▶ Fan Control Operation

When paired to PIXIE098 module configuration is automatically applied.

### ▶ Applications

Ceiling fan control, motorised blind control, fine tuned dimming control of devices and groups.

### ▶ Whats in the box

1 x Multifunction controller, 1 x standard length dial, 1 x long neck dial for other wall plates like PIXIE Ambience wall plates

### ▶ Accessories

Long and short neck dial included in package



SCAN ME

Download the PIXIE and  
PIXIE PLUS Apps



#SMFRBTAS

Multifunction Rotary Controller



Multifunction secondary device which when paired with PIXIE devices, groups or scenes, delivers a new interactive experience of the PIXIE smart home system with an intuitive interface.

**Ideal for Ceiling Fan Control<sup>^</sup> and Motorised Blind Control.**

## Features

- Rotary dial for intuitive interactions
- Intuitive LED feedback through dial for interactive user experience
- Requires Active + Neutral connection from anywhere to operate
- Requires at least 1 PIXIE Master device to provide function
- Fits into most Australian wall plates, max. 6 gang installation
- Can pair and control every PIXIE master device, control up to 2 scenes in PIXIE app; control up to 6 scenes in PIXIE PLUS app; pair and control groups
- Generation 3 product compatible with Gen 1 and Gen 2 products

Full operating detail provided in installation manual

## Electrical

Power Supply	240VAC/ 50 Hz
Min/ Max loads*	No connected load
Operating ambient min/max (°C)	0 to 40°
BT Mesh Typical wireless range	15 metres typical indoors **
IP Rating	IP20
Dimensions	54x24x24

<sup>^</sup> DC Ceiling fan control of Hunter Pacific DC V2 fans with PIXIE098 module also installed

\*Subject to product capability, this size load may require the inclusion of the LOAD capacitor included in the product carton.

\*\* Depending on building materials and construction.



## PIXIE multi function Rotary Controller



#SMFRBTAS

### Related products

PIXIE Smart Dimmer  
#SDD300BTAM



PIXIE 600W Switch  
#SWL600BTAM



PIXIE Multifunction  
#SMFBTAS



PIXIE Gateway G3  
#SGW3BTAM



## DC Ceiling Fan Controller

Designed for use with HUNTER PACIFIC INTERNATIONAL DC V2 Ceiling Fans.



Simply insert the Hunter Pacific PIXIE module (Part #: PIXIEO98) into the Hunter Pacific Ceiling fan receiver base and PIXIE-FY the full range of DC V2 fans.

Simple Multiway Fan Control is now possible and freedom from mounting remote controls onto walls to maintain room aesthetics.

Home owners can control ceiling fan speed and light functions from this single, familiar rotary dial interface.

## Motorised Blind & Curtain Controller

When used in combination with the PIXIE Blind and Signal Controller (PC206BS/R/BTAM), simple open, stop, close functionality is provided from a single interface.

This reduces wall clutter and provides intuitive directional control and a simple push to stop.

## Wiring Diagram

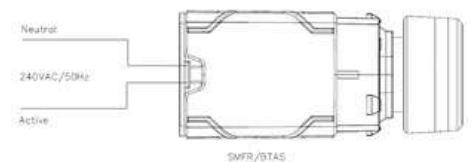
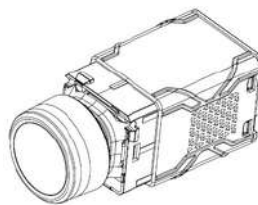

## PIXIE fits in

PIXIE fits in to a huge range of Australian wall plates



SCAN ME



SCAN ME

Download the PIXIE and  
PIXIE PLUS Apps



## PIXIE Multiway Switch

#S2WBTAS

 Bluetooth®

### ▶ Basic operation

- 1 click to activate/ deactivate device to which it is paired and electrically connected.
- 4 clicks manual pairing
- 9 clicks reset device

### ▶ Applications

Perfect for 2-way, 3-way control of electrically connected PIXIE Master devices - Dimmer or Switch only.

### ▶ Whats in the box

1 x Multiway switch, 1 x silicone adaptor/spacer, 3 x switch caps, installation instructions

### ▶ Accessories

PIXIE Ambience wall and faceplates in White/Grey/Black



SCAN ME

Download the PIXIE and  
PIXIE PLUS Apps



#S2WBTAS  
PIXIE Multiway Switch



This is a Secondary PIXIE device which requires a Master Dimmer or Master Switch with which to operate. The Multiway Switch provides the ability for 2way and 3way control for traditional wiring arrangements for 2 way and 3 way operation. Comes with Bluetooth Mesh Technology.

## Features

- Requires Active + switched active wired in parallel
- Requires at least 1 PIXIE Master device to provide function
- Fit most branded switch plates and PIXIE Ambience plates
- Maximum 3 way operation with 2 x Multiway Switches electrically connected to the Master load controller (Dimmer or Switch)
- Best used where no neutral is present and straps have been installed or are already in place.
- LED indicator ONLY operates when pressed, thereafter no LED indicator is lit.
- Generation 3 product compatible with Gen 1 and Gen 2 products

## Electrical

Power Supply	220-240VAC
Min/ Max loads*	9*/350W
Operating ambient min/max (°C)	0 to 40°
Typical wireless range	15 metres typical indoors **
IP Rating	IP20

\*Subject to product capability, this size load may require the inclusion of the LOAD capacitor included in the product carton.  
\*\* Depending on building materials and construction.



## PIXIE Multiway Switch

#S2WBTAS



### Related products

PIXIE Smart Dimmer  
#SDD300BTAM



PIXIE Smart Dimmer  
#SDD350BT



PIXIE Smart Timer  
#STS350BT



PIXIE 600W Switch  
#SWL600BTAM



## Wiring Diagram

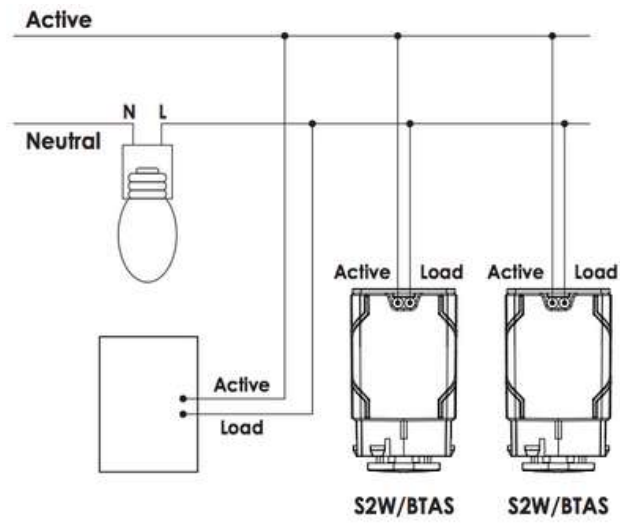

## PIXIE fits in

PIXIE fits in to a huge range of Australian wall plates



SCAN ME



SCAN ME

Download the PIXIE and  
PIXIE PLUS Apps





## PIXIE Ambience Touch Panel

#STP54BTAS



### ▶ Basic operation

- Colour touch screen allows control of all PIXIE devices, groups, scenes.
- 4 x quick access multifunction buttons can be configured for device, group and scene control

### ▶ Applications

Ideal for larger homes with many PIXIE devices where a central and permanent control hub is required.

### ▶ Whats in the box

PIXIE Touch Panel, white cover, mounting template, steel mounting bracket and hardware, instruction and installation manual

### ▶ Accessories

POE or DC power supply required for operation - not included in box. Requires PIXIE PLUS App and PIXIE Gateway Gen3 to operate.



SCAN ME

Download the PIXIE and  
PIXIE PLUS Apps



**PIXIE Ambience Touch  
Panel #STP54BTAS**



The PIXIE Ambience Touch Panel elevates the smart home experience with a native, centralised, wall mounted hub to control every PIXIE device in the home. Featuring a 5.5inch full colour touch screen and 4 x PIXIE Multifunction Control buttons on-board for quick access to common devices, groups and scenes.

## Features

- Simple installation with choice between PoE or simple DC power supply for power and LAN or WiFi for network connection
- Easy to mount using provided template and sturdy wall mounting bracket, directly into standard Australian mounting hardware and single plate penetrations.
- Proximity sensor to illuminate screen on approach for rapid access
- Light level sensor automatically dims touchscreen based on ambient light for superb visual comfort
- Screen saver, time & weather function to save screen add utility and / or black out completely according to customer configuration
- Control through multiple PIXIE Gateways for very large homes
- Requires the PIXIE Gateway (SGW3/BTAS\*) and free PIXIE PLUS App to operate.

## Electrical

Power <sup>^</sup>	15w DC minimum
PoE	via RJ45 @ max 48VDC
Screen size	5.5inch full colour
Operating ambient min/max (°C)	0 to 40°
Network Connectivity	LAN cable or 2.4GHz WiFi
IP Rating	IP20

<sup>^</sup> Recommend use of the SAL PLUTO 15DV, constant voltage driver if not using POE to power touch panel.



## PIXIE Ambience Touch Panel #STP54BTAS



### Related products

PIXIE Smart Dimmer  
#SDD300BTAM



PIXIE 600W Switch  
#SWL600BTAM



PIXIE Multifunction  
#SMFBTAS



PIXIE Gateway G3  
#SGW3BTAM



## Additional details



Pull out menu acts as a reminder of button functions and fast multifunction button re-configuration tool.

Each Multifunction button can be assigned a single-tap and / or double-tap function for fast access to devices, groups and scenes.

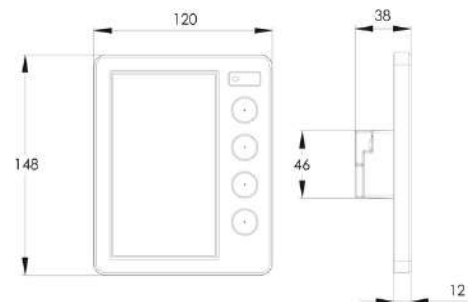

Powered by either POE or a low voltage power supply for simple installation. Fits into a standard single-gang wall plate mount and provided with metal mounting bracket and template for precise mounting.

\*Ambience Touch Panel will operate with Gen1 Gateway (SGW/BT), however, the user experience will be enhanced using Gen3 Gateway.

## PIXIE fits in

PIXIE fits in to a huge range of Australian wall plates



SCAN ME



SCAN ME

Download the PIXIE and  
PIXIE PLUS Apps



# PIXIE Gateway

#SGW3BTAM



## Basic operation

- Press and hold for 5 seconds to reboot
- 9 clicks reset device

## Applications

For out-of-home control, monitoring and voice assistant integration applications.

## Whats in the box

1 x PIXIE Gateway, 1 x AC Adaptor, 1 x LAN cable, installation instructions

## Accessories

Requires free PIXIE PLUS App to operate. Four LED indicators for clear status display & feedback.



SCAN ME

Download the PIXIE and  
PIXIE PLUS Apps



#SGW3BTAM

PIXIE Gateway Gen3



This device is a bridge between the internet and the PIXIE Bluetooth mesh inside the home, introducing additional features and functionality such as out of home control and voice control capabilities. The Gen3 version introduces a LAN / RJ45 port for hard wired connections in addition to Wireless (2.4GHz) connectivity. The PIXIE Gateway Gen3 works with the PIXIE system and needs the free PIXIE Plus app.

## Features

- Plug and play device with necessary AC adaptor included
- Choose between wireless or wired connection to local network
- PIXIE Connected Home Cloud for backup of PIXIE Home configuration
- Out of home control capabilities for the PIXIE smart home
- Integrate with voice assistants and other Cloud services and devices
- Schedule scenes, (as well as groups and devices as per the PIXIE App)
- PIXIE Gateway is an OPTIONAL device and is only needed if out-of-home control, scene scheduling or voice controls is desired.

## Electrical

Input	15V DC - 1A
Operating ambient min/max (°C)	0 to 40°
Typical BT wireless range	15 metres typical indoors <sup>✱</sup>
IP Rating	IP20
Wi-Fi Connectivity	Wi-Fi 802.11 g/b/n, 2.4Ghz
LAN Port	1 x RJ45
Device Support	Up to 128 Gen3 Master

<sup>✱</sup> Depending on building materials and construction.

## PIXIE Gateway #SGW3BTAM



### Related products

#### PIXIE Smart Dimmer #SDD300BTAM



#### PIXIE 600W Switch #SWL600BTAM



#### PIXIE Multifunction #SMFBTAS



#### PIXIE Touch Panel #STP54BTAS



## Voice Assistant / System Compatibility



## Product Detail

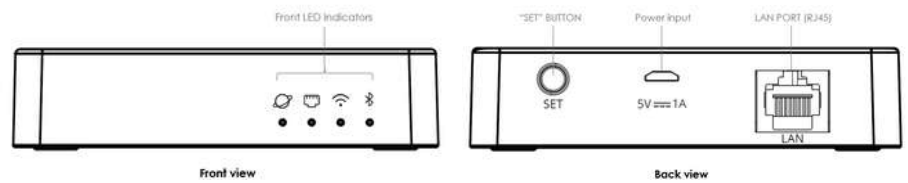

## Indicator Status

Indicator	Internet	Lan (RJ45 port)	Wi-Fi	Bluetooth
<b>Blink (once per 1 second) in red</b>	This internet connection is waiting to be configured	This LAN (RJ45 port) connection is waiting to be configured	This Wi-Fi connection is waiting to be configured	This gateway is waiting to be configured
<b>Solid red</b>	Internet connection fail	Fail to connect to the router (local area network) via RJ45 port	Wi-Fi connection to the router (local area network) is failed	Bluetooth connection fail
<b>Blink (once per 1 second) in blue</b>	The internet connection is configuring	The LAN (RJ45 port) connection is configuring	The Wi-Fi connection is configuring	The Bluetooth connection is configuring
<b>Blink slowly (once per 10 seconds) in blue</b>	The gateway is currently working under offline mode (does not require internet connection to work)	The gateway is currently <b>NOT</b> using RJ45 port to connect to the router (local area network)	The gateway is currently <b>NOT</b> using Wi-Fi to connect to the router (local area network)	-
<b>Solid blue</b>	The internet connection is successful	The gateway is using RJ45 port to connect to the router (local area network), and the connection is successful	The gateway is using Wi-Fi to connect to the router (local area network), and the connection is successful	The Bluetooth connection is successful

# PIXIE fits in

PIXIE fits in to a huge range of Australian wall plates



SCAN ME



SCAN ME

Download the PIXIE and  
PIXIE PLUS Apps



## PIXIE Smart Dimmer

#SDD350BT



### Basic operation

- 1 click operate lights on/off
- To dim, long press and hold.
- 2 clicks go to maximum output
- 4 clicks manual pairing
- 5 clicks set minimum dim
- 9 clicks reset device

### Applications

Residential dwellings for retrofit, renovation and new build; apartments; hotels and hospitality venues.

### Whats in the box

1 x Smart dimmer, 1 x silicone adaptor/spacer, 3 x switch caps, 1 x capacitor, installation instructions

### Accessories

PIXIE Ambience wall and faceplates in White/Grey/Black



#SDD350BT  
PIXIE Smart Dimmer



Push button smart dimmer for lighting control with wireless Bluetooth Mesh Technology in residential, hotel and hospitality spaces. Comes with 24hour/7 Day scheduling, Groups, Scenes and mobile app control and configuration.

## Features

- Suitable for dimming LED, tungsten, halogen light sources
- Fit most branded switch plates and PIXIE Ambience plates
- Smart functions and configuration via phone/tablet with PIXIE or PIXIE Plus app
- Memory dimmer function returns to previous dimmed level from off
- Over temperature protection, overload protection, short circuit protection
- Complies with Australian and New Zealand: AS/NZS 60669.2.1
- LED indicator shines bright when the dimmer is on, and faint when the dimmer is off for locating in the dark
- LED indicator can be enabled and disabled through the PIXIE or PIXIE Plus app, when disabled, the indicator is off at OFF state, and lit at ON state

## Electrical

Power Supply	220-240VAC
Min/ Max loads*	2W*/350W - 200VA LED
Dimming Method	Phase cut - Trailing edge
Operating ambient min/max (°C)	0 to 40°
Typical wireless range	15 metres typical indoors **
IP Rating	IP20



SCAN ME

Download the PIXIE and  
PIXIE PLUS Apps



\*Subject to product capability, this size load may require the inclusion of the LOAD capacitor included in the product carton.  
\*\* Depending on building materials and construction.

## PIXIE Smart Dimmer

#SDD350BT G2



### Related products

PIXIE Smart Dimmer  
#SDD300BTAM



PIXIE Timer Switch  
#STS350BT



PIXIE 600W Switch  
#SWL600BTAM



PIXIE Multifunction  
#SMFBTAS



## Wiring Diagram

SDD350BT G2 - Standard wiring diagram

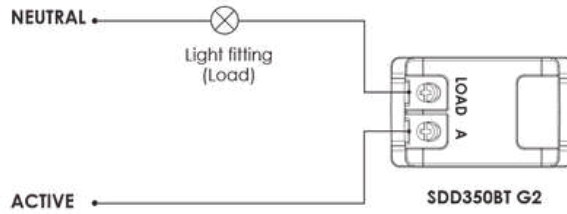

SDD350BT G2 - Optional wiring diagram

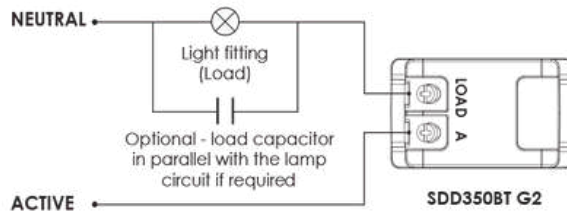

## Dimensions

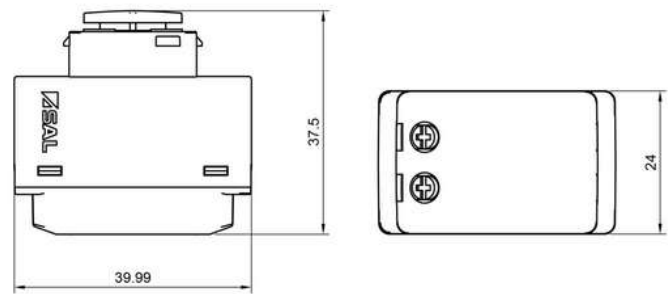

## PIXIE fits in

PIXIE fits in to a huge range of Australian wall plates

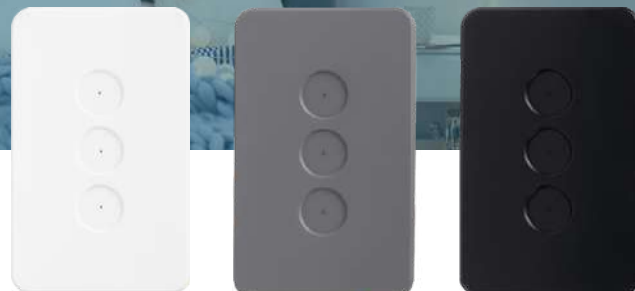

SCAN ME



SCAN ME

Download the PIXIE and  
PIXIE PLUS Apps



## PIXIE Smart Switch

#SWL350BT



### ▶ Basic operation

- 1 click operate lights on/off
- 4 clicks manual pairing
- 9 clicks reset device

### ▶ Applications

Residential dwellings for retrofit, renovation and new build; apartments; hotels and hospitality venues.

### ▶ Whats in the box

1 x Smart switch, 1 x silicone adaptor/spacer, 3 x switch caps, 1 x capacitor, installation instructions

### ▶ Accessories

PIXIE Ambience wall and faceplates in White/Grey/Black



#SWL350BT  
PIXIE Smart Switch



Push button smart switch for controlling lighting and other loads with wireless Bluetooth Mesh Technology in residential, hotel and hospitality spaces. Comes with 24hour/7 Day scheduling, Groups, Scenes and mobile app control and configuration.

## Features

- Suitable for switching lighting and other compatible loads
- Loads greater than 350w control possible via contactor (by others).
- Fit most branded switch plates and PIXIE Ambience plates
- Smart functions and configuration via phone/tablet with PIXIE Apps
- Over temperature protection, overload protection, short circuit protection
- Complies with Australian and New Zealand: AS/NZS 60669.2.1
- LED indicator shines bright when the dimmer is on, and faint when the dimmer is off for locating in the dark
- LED indicator can be enabled and disabled through the PIXIE or PIXIE Plus app, when disabled, the indicator is off at OFF state, and lit at ON state

## Electrical

Power Supply	220-240VAC
Min/ Max loads*	13W*/350W - 200V AC LED
Max inductive loads	80V AC
Operating ambient min/max (°C)	0 to 40°
Typical wireless range	15 metres typical indoors **
IP Rating	IP20

\*Subject to product capability, this size load may require the inclusion of the LOAD capacitor included in the product carton.  
\*\* Depending on building materials and construction.



SCAN ME

Download the PIXIE and  
PIXIE PLUS Apps



## PIXIE Smart Switch

#SWL350BT G2



### Related products

PIXIE Smart Dimmer  
#SDD350BT



PIXIE Timer Switch  
#STS350BT



PIXIE 600W Switch  
#SWL600BTAM



PIXIE Multifunction  
#SMFBTAS



## Wiring Diagram

SWL350BT G2 - Standard wiring diagram

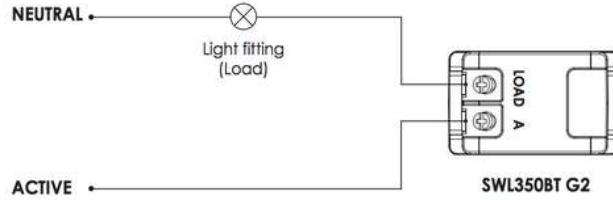

SWL350BT G2 - Optional wiring diagram

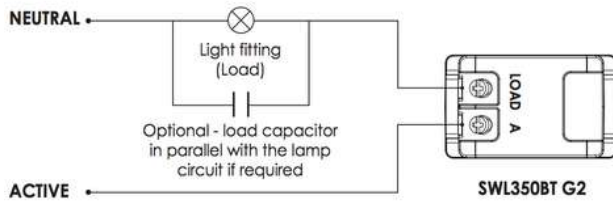

The SWL350BT G2 is a 2 wire product, the capacitor provided in the carton operates as a load correction device to assist achieving minimum load levels and improve compatibility performances.

## Dimensions

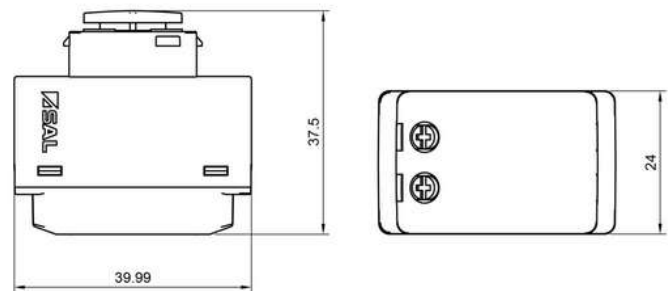

## PIXIE fits in

PIXIE fits in to a huge range of Australian wall plates



SCAN ME



SCAN ME

Download the PIXIE and  
PIXIE PLUS Apps





## PIXIE Smart Power Point

#SPO23BTAM



### Basic operation

- 1 click to turn on/ off left and right outlets respectively.
- 4 clicks manual pairing
- 9 clicks reset device
- Press and hold left+right button for >12sec to activate/ deactivate child lock

### Applications

Energy management control of appliances in kitchens and bathrooms, phone chargers, wall and floor lamps

### Whats in the box

1 x Smart power point, 1 x PIXIE Ambience white faceplate, installation instructions

### Accessories

PIXIE Ambience faceplates in Grey & Black. Also has 3 interchangeable faceplates designed to suit popular plate styles in gloss white and colours.



SCAN ME

Download the PIXIE and PIXIE PLUS Apps



#SPO23BTAM

PIXIE Smart Power Point (GPO)



A smart socket outlet designed to operate as a standard 250V / 10A double wall socket and communicate with PIXIE devices via the centre mount Multifunction control. Interchangeable cover plates and caps available and comes with Bluetooth Mesh Technology, Groups, Scenes, Schedules, Timers.

## Features

- Control the GPO via a standard push button action and PIXIE Apps
- Each socket individually controllable
- Schedule each socket individually
- The PIXIE multifunction control (middle button) will pair with all PIXIE devices, groups and scenes anywhere in the PIXIE enabled home.
- Designed with a Child lock function when operating with the PIXIE Plus app and activation /deactivation via front buttons
- Easy identification via colour-coded terminals for installation by authorised electricians
- Insulated screw caps for combination flat/Philips head screws

## Electrical

Power Supply	250V AC @ 50Hz
Max loads	10A max.
Operating ambient min/max (°C)	0 to 40°
Typical wireless range	15 metres typical indoors **
IP Rating	IP20
Energy Monitoring	Per socket, in PIXIE Plus App
Compliance	AS/NZS 3112:2017



## PIXIE Smart Power Point

#SPO23BTAM



### Related products

PIXIE Touch Panel  
#STP54BTAS



PIXIE Smart Dimmer  
#SDD300BTAM



PIXIE Smart Timer  
#STS600BTAM



PIXIE 600W Switch  
#SWL600BTAM



## Dimensions

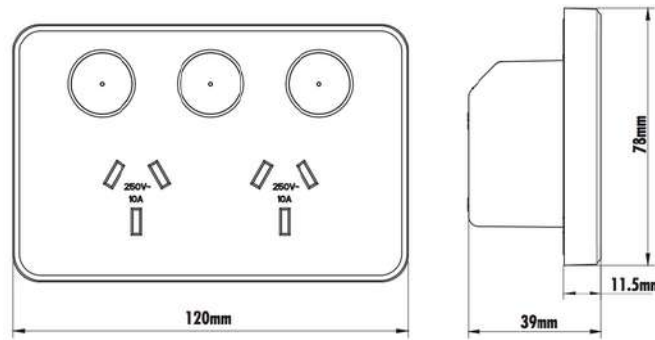

The Middle button is a PIXIE multifunction control button. It can be paired with any PIXIE master device to achieve multiway control, or to configured to control a group or a scene with the PIXIE or PIXIE Plus app

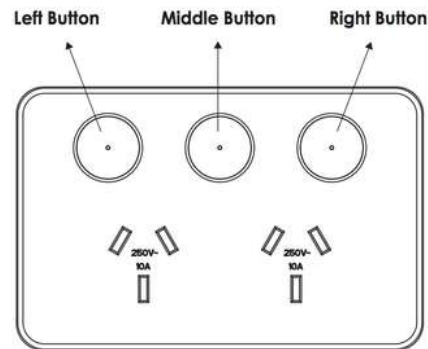

## Faceplate Options - Colours



Faceplate Included  
Gloss White  
Round, sunken buttons



Faceplate SPO23AG/BTP  
Matt Gray  
Round, sunken buttons



Faceplate SPO23AB/BTP  
Matt Black  
Round, sunken buttons

## Faceplate Options - Design



Faceplate only  
SPO23CW-BTP  
White only

Styling characteristics appeal to homeowners who like classic faceplates.



Faceplate only  
SPO23IW-BTP  
White only

Styling characteristics appeal to homeowners who like modern faceplates.



Faceplate only  
SPO23EW-BTP  
White only

Styling characteristics appeal to homeowners who like HPM™ faceplates.

SCAN ME



Download the PIXIE and  
PIXIE PLUS Apps



## PIXIE Smart Plug

#ESS105BT

 Bluetooth®

### ▶ Basic operation

- 1 click to turn on/ off socket
- 4 clicks manual pairing
- 9 clicks reset device
- Long press the push button until LED indicator flashes to turn ON/OFF the USB output

### ▶ Applications

Energy management control of appliances in kitchens and bathrooms, phone chargers, wall and floor lamps

### ▶ Whats in the box

1 x Smart plug, installation instructions

### ▶ Accessories

None



SCAN ME

Download the PIXIE and PIXIE PLUS Apps



#ESS105BT  
PIXIE Smart Plug



A portable smart plug with a 1.5A USB port. Can be plugged into any standard Australian power outlet and control any appliances or lighting connected to the rated load capacity. Comes with Bluetooth Mesh Technology, Groups, Scenes, Schedules, Timers.

## Features

- DIY Plug and play device with full PIXIE smart functionality
- Control the smart plug via the standard push button action and PIXIE Apps
- Integral USB port, 5V DC, 1.5A
- Socket outlet and USB port can be separately scheduled and controlled
- Compliant to AS/NZS 3105:2014, AS/NZS 60950.1:2015

## Electrical

Power Supply	250V AC @ 50Hz
Max load resistive	1500W
Max load capacitive/ inductive	800W
Operating ambient min/max (°C)	0 to 40°
Typical wireless range	15 metres typical indoors **
IP Rating	IP20

\*\* Depending on building materials and construction.



## PIXIE Smart Plug

#ESS105BT



### Related products

PIXIE Smart GPO  
#SPO23BTAM



PIXIE Smart Dimmer  
#SDD300BTAM



PIXIE Smart Timer  
#STS350BT



PIXIE 600W Switch  
#SWL600BTAM



## Dimensions

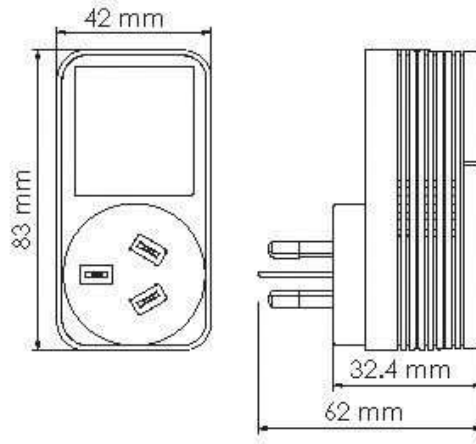

## PIXIE fits in

PIXIE fits in to a huge range of Australian wall plates



SCAN ME



SCAN ME

Download the PIXIE and  
PIXIE PLUS Apps



## PIXIE Smart LED Strip Controller

#LT8915DIMBT

 Bluetooth

### ▶ Basic operation

- 1 click operate LED on/off
- To dim, long press and hold.
- 2 clicks go to maximum output
- 4 clicks manual pairing
- 9 clicks reset device

Using 'control-button' on device and momentary inputs

### ▶ Applications

Residential dwellings for retrofit, renovation and new build; apartments; hotels and hospitality venues.

### ▶ Whats in the box

1 x LED Strip Controller, installation instructions

### ▶ Accessories

Bell Press mechs from 3rd party for optional connection to bell-press inputs.



SCAN ME

Download the PIXIE and PIXIE PLUS Apps



#LT8915DIMBT

PIXIE Smart LED Strip Controller



PIXIE LED strip controller enables dimming of most manufacturer's LED strip via momentary switch, smart phone App or PIXIE Multifunction controllers. Comes with 24hour/7 Day scheduling, Groups, Scenes and mobile app control and configuration.

## Features

- Suitable for controlling intensity (dimming) of LED strips in a single colour in 12v and 24v.
- Memory function activated by dip switch to toggle and memorise the status if a power outage occurs
- Seperate, optional connection of 3rd-party bell-press/ momentary inputs for simple wall control operation and integration possibilities.
- Compatible with PIXIE Multifunction control, Multifunction remote control, Timer control
- Connect a power repeater to allow extension to the power capacity (extra power supply required) for very long LED runs.

## Electrical

Input	12 - 24V
Min/ Max loads*	12V: 0/214W, 24V: 0/423W
Operating ambient min/max (°C)	-10 to 45°
Typical wireless range	15 metres typical indoors **
IP Rating	IP20

\*\* Depending on building materials and construction.



## PIXIE Smart LED Controller

#LT8915DIMBT



### Related products

PIXIE Multifunction  
#SMFBTAS



PIXIE Smart RGB LED Controller  
#LT8915RGBBT



PIXIE Smart Dimmer  
#SDD300BTAM



PIXIE 600W Switch  
#SWL600BTAM



## Wiring Diagram

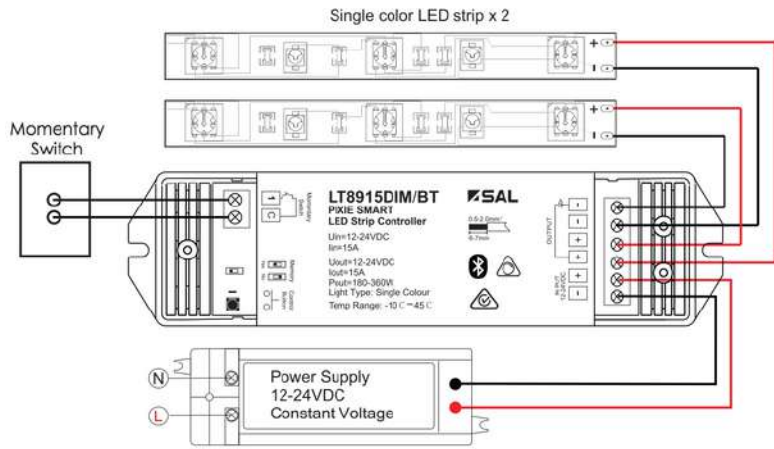

Power supply pictured to be purchased separately as needed to match the connected LED strip load and length.

## Dimensions

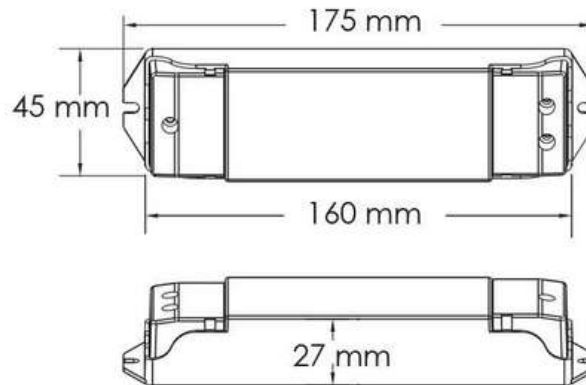

## PIXIE fits in

PIXIE fits in to a huge range of Australian wall plates



SCAN ME



SCAN ME

Download the PIXIE and  
PIXIE PLUS Apps



## PIXIE Smart RGB LED Strip Controller

#LT8915RGBBT



### ▶ Basic operation

- 1 click operate LED on/off
- To dim, long press and hold.
- 2 clicks go to maximum output
- 3 click change colour in white-red-green-blue-white order
- 4 clicks manual pairing
- 9 clicks reset device

Using 'control-button' on device and momentary inputs

### ▶ Applications

Residential dwellings for retrofit, renovation and new build; apartments; hotels and hospitality venues.

### ▶ Whats in the box

1 x RGB LED Strip Controller, installation instructions

### ▶ Accessories

Bell Press mechs from 3rd party for optional connection to bell-press inputs.



SCAN ME

Download the PIXIE and PIXIE PLUS Apps



#LT8915RGBBT

PIXIE Smart RGB LED Strip Controller



PIXIE LED strip controller enables dimming of most manufacturer's RGB LED strip via momentary switch, smart phone App or PIXIE Multifunction controllers. Comes with 24hour/7 Day scheduling, Groups, Scenes and mobile app control and configuration.

## Features

- Suitable for controlling intensity (dimming) and colour of RGB LED strips in 12v and 24v.
- Memory function activated by dip switch to toggle and memorise the status if a power outage occurs
- 2 x separate, optional connection of 3rd-party bell-press/ momentary inputs for simple wall control operation and integration possibilities.
- Compatible with PIXIE Multifunction control, Multifunction remote control, Timer control
- Connect a power repeater to allow extension to the power capacity (extra power supply required) for very long LED runs.

## Electrical

Input	12 - 24V
Min/ Max loads*	12V: 0/180W, 24V: 0/360W
Operating ambient min/max (°C)	-10 to 45°
Typical wireless range	15 metres typical indoors **
IP Rating	IP20

\*\* Depending on building materials and construction.



## PIXIE Smart RGB LED Controller

#LT8915RGBBT



### Related products

PIXIE Multifunction #SMFBTAS



PIXIE Smart LED Controller #LT8915DIMBT



PIXIE Smart Dimmer SDD300BTAM



PIXIE 600W Switch #SWL600BTAM



## Wiring Diagram

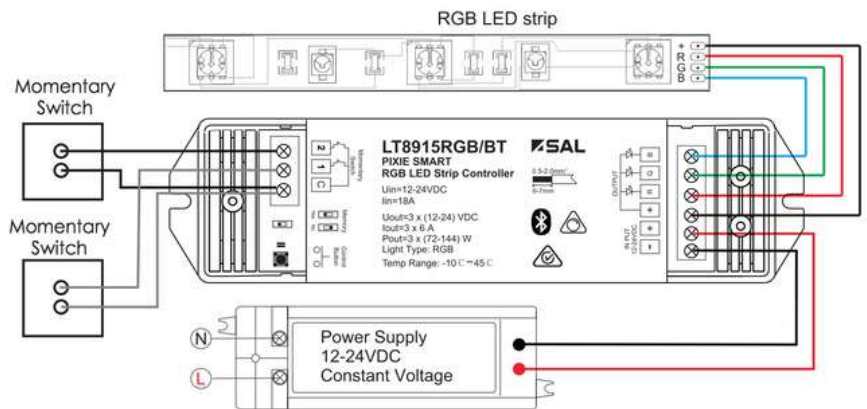

Power supply pictured to be purchased separately as needed to match the connected LED strip load and length.

## Dimensions

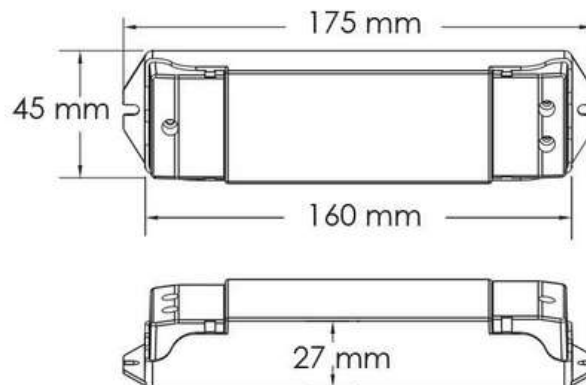

## PIXIE fits in

PIXIE fits in to a huge range of Australian wall plates



SCAN ME



SCAN ME

Download the PIXIE and PIXIE PLUS Apps





## PIXIE Blind & Signal Controller

#PC206BS-R-BTAM

 Bluetooth

### ▶ Basic operation

- 1 click Relay closes quickly then opens
- Long press relay closes until pressure is released from the button
- 4 clicks manual pairing
- 9 clicks reset device

Using 'control-buttons' on device and momentary inputs

### ▶ Applications

Blind /curtain control for residential dwellings for retrofit, renovation and new build; apartments; hotels and hospitality venues.

### ▶ Whats in the box

1 x Blind and Signal Controller, installation instructions

### ▶ Accessories

Bell Press mechs from 3rd party for optional connection to bell-press inputs.



#PC206BS-R-BTAM  
PIXIE Blind & Signal Controller



Control of 3-wire and 4-wire motorise blinds, curtains, awnings, projector screens, garage doors + dry contact outputs for on-site integration with 3rd party systems that accept dry contact / volt free inputs. Comes with 24hour/7 Day scheduling, Groups, Scenes and mobile app control and configuration.

## Features

- Dual 6Amp relays for direct control and signal control of 4 and 3 wire blind, curtain motors respectively
- Dry contact interfacing to 3rd party equipment for on-site integration
- Interlock switch provided offering protection to 4 wire motors when activated, preventing both relays from actuating simultaneously
- Optional bell press inputs for connection of 3rd-party bell-press/momentary inputs for simple wall control operation and integration possibilities.
- Compatible with PIXIE Multifunction control, Multifunction remote control
- Outputs configurable as PULSE, DOUBLE PULSE or TIMED PULSE for a wide variety of control and signalling operations

## Electrical

Input(V)(Hz)	240/50
Max loads	6A per channel (2 channels)
Operating ambient min/max (°C)	0 to 60°
Typical wireless range	15 metres typical indoors **
IP Rating	IP20

\*\* Depending on building materials and construction.



SCAN ME

Download the PIXIE and  
PIXIE PLUS Apps



## PIXIE Blind and Signal Controller

#PC206BS-R-BTAM



### Related products

PIXIE Multifunction  
#SMFBTAS



PIXIE Dual Relay  
#PC206DR-R-BTAM



PIXIE Translator  
#PC100T-R-BTAS



PIXIE Gateway G3  
#SGW3BT



## Wiring Diagram

Buttons and terminals:

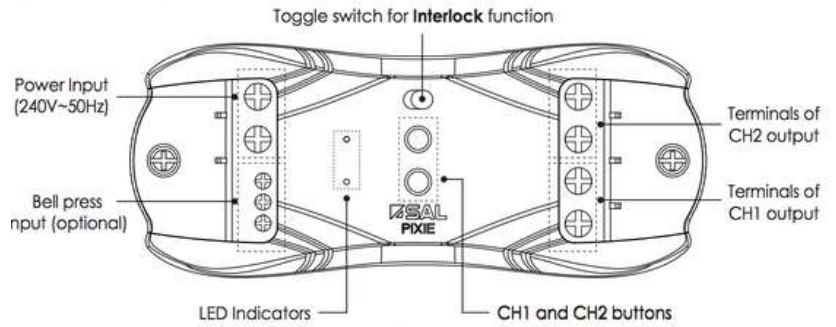

Figure 1

Wiring diagram (Typical dry contact signal output)

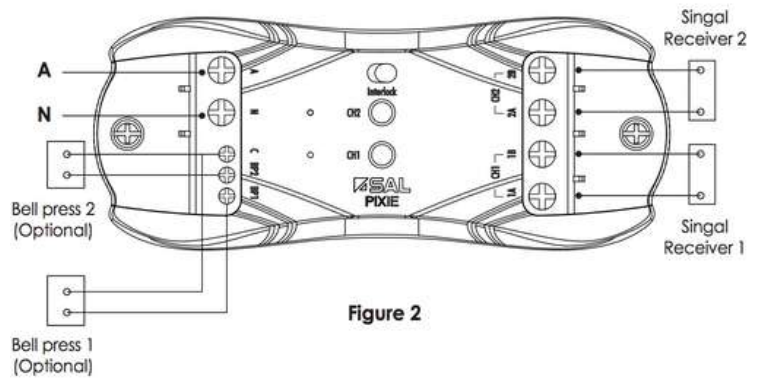

Figure 2

## PIXIE fits in

PIXIE fits in to a huge range of Australian wall plates



SCAN ME



SCAN ME

Download the PIXIE and  
PIXIE PLUS Apps



## PIXIE Dual Relay Controller

#PC206DR-R-BTAM

 Bluetooth

### ▶ Basic operation

- 1 click toggle relay close/open
- 4 clicks manual pairing
- 9 clicks reset device

Using 'control-buttons' on device and momentary inputs

### ▶ Applications

Larger load switching control for residential dwellings for retrofit, renovation and new build; apartments; hotels and hospitality venues.

### ▶ Whats in the box

1 x Dual Relay Controller, installation instructions

### ▶ Accessories

Bell Press mechs from 3rd party for optional connection to bell-press inputs.



SCAN ME

Download the PIXIE and PIXIE PLUS Apps



#PC206DR-R-BTAM  
PIXIE Blind & Signal Controller



Designed for larger load switching in the PIXIE ecosystem, with 2 6Amp relays which can be controlled independently. This provides for interesting electrical control scenarios with 3-wire sensors, AC ceiling fan speed control. Comes with 24hour/7 Day scheduling, Groups, Scenes and mobile app control and configuration.

## Features

- Dual 6Amp relays for direct control of connected loads
- 3-wire motions sensor integration using 3rd party sensors
- AC Ceiling fan control - 3 speed + off - using capacitor from fans
- Memory switch provided when the supply is terminated and resupplied, both outputs will restore to the state before the outage.
- Optional bell press inputs for connection of 3rd-party bell-press/momentary inputs for simple wall control operation and integration possibilities.
- Compatible with PIXIE Multifunction control, Multifunction remote control
- No minimum output requirements for switching loads

## Electrical

Input(V)(Hz)	240/50
Max loads (Resistive)	6A per channel (2 channels)
Operating ambient min/max (°C)	0 to 60°
Typical wireless range	15 metres typical indoors **
IP Rating	IP20

\*\* Depending on building materials and construction.



## PIXIE Dual Relay Controller

#PC206DR-R-BTAM



### Related products

PIXIE Multifunction  
#SMFBTAS



PIXIE Blind & Signal  
#PC206BS-R-BTAM



PIXIE Translator  
#PC100T-R-BTAS



PIXIE Gateway G3  
#SGW3BT



## Wiring Diagram

### Buttons and terminals

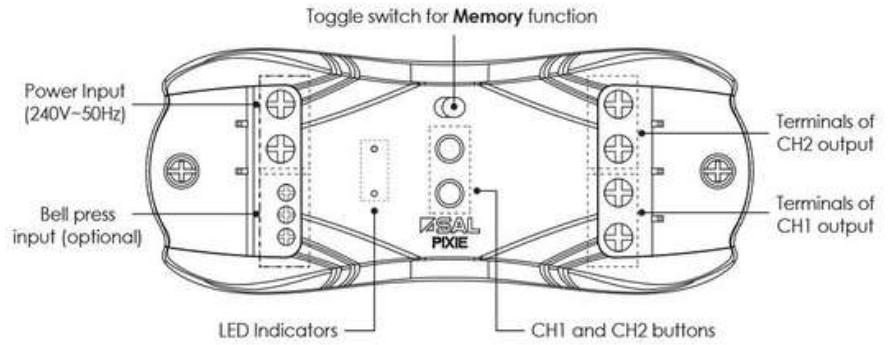

### Wiring diagram

(Typical application)

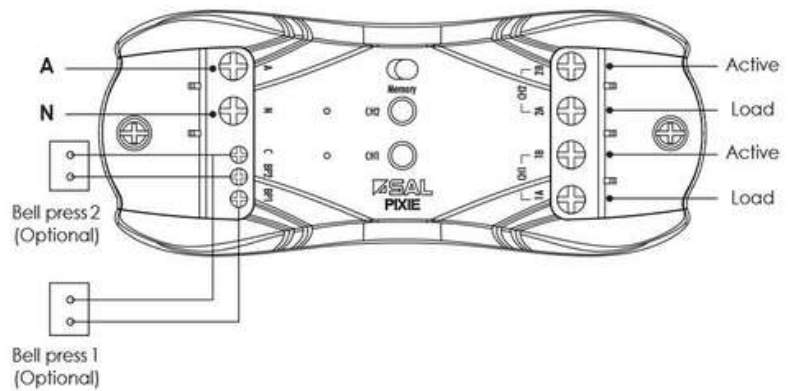

## PIXIE fits in

PIXIE fits in to a huge range of Australian wall plates

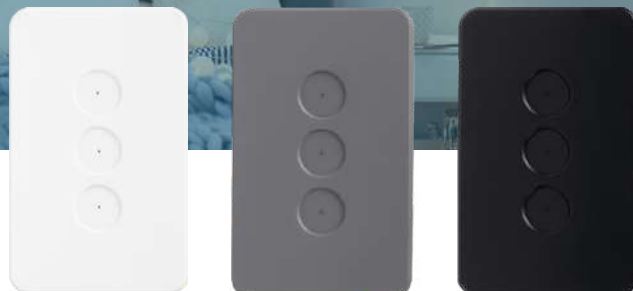

SCAN ME



SCAN ME

Download the PIXIE and  
PIXIE PLUS Apps



## PIXIE Translator

#PC100T-R-BTAS



### ▶ Basic operation

- 1 click Depends upon the program result
- 4 clicks manual pairing
- 9 clicks reset device

Using 'control-buttons' on device and momentary inputs

### ▶ Applications

Low level dry contact / volt free interfacing from other PIXIE devices and 3rd party systems for on-site integration scenarios

### ▶ Whats in the box

1 x Translator, installation instructions

### ▶ Accessories

Bell Press mechs from 3rd party for optional connection to bell-press inputs.



#PC100T-R-BTAS  
PIXIE Blind & Signal Controller



Single signal input for connecting a momentary switch, a toggle switch, voltage-free contacts of devices that can generate dry contact signals. It enables integration between PIXIE and other systems. Comes with 24hour/7 Day scheduling, Groups, Scenes and mobile app control and configuration.

## Features

- Module to provide 3rd party, on-site interface with PIXIE smart home
- Dry contact / low level / volt free integration of PIXIE system from any system capable of providing necessary dry contact
- Ideal for receiving low-level inputs from sensors, alarm systems, audio visual systems, intercom systems
- Can accept both a PULSE signal and / or a Latch/Unlatch signal for logic processing
- LED indicator colour is white when the product is new or has been reset, LED indicator colour is amber when operating in "Latch" mode, the LED indicator colour is green when operating in "Pulse" mode.

## Electrical

Input(V)(Hz)	240/50
Standby Power	0.5 Watts
Operating ambient min/max (°C)	0 to 60°
Typical wireless range	15 metres typical indoors **
IP Rating	IP20

\*\* Depending on building materials and construction.



SCAN ME

Download the PIXIE and  
PIXIE PLUS Apps



## PIXIE Translator

#PC100T-R-BTAS



## Related products

PIXIE Multifunction  
#SMFBTAS



PIXIE Blind & Signal  
#PC206BS-R-BTAM



PIXIE Dual Relay  
#PC206DR-R-BTAM



PIXIE Gateway G3  
#SGW3BT



## Wiring Diagram

### Buttons and terminals

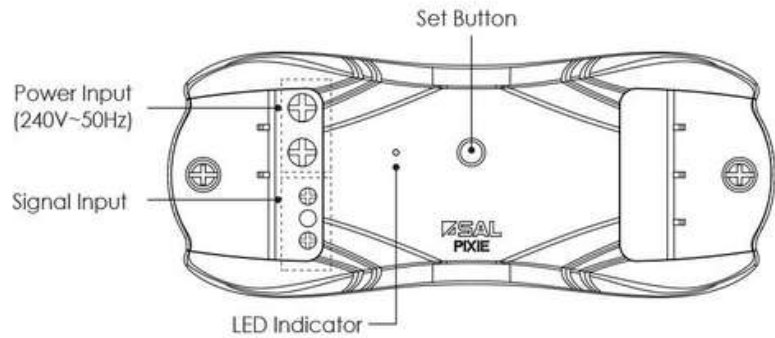

### Wiring diagram

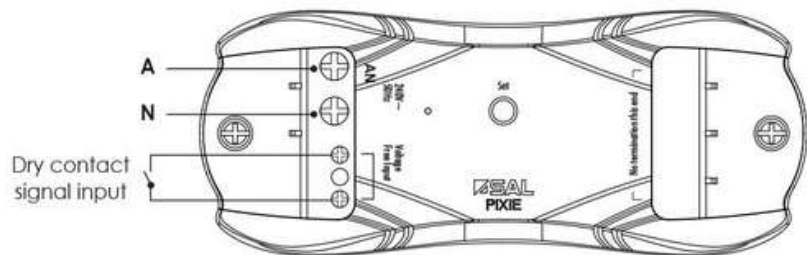

## PIXIE fits in

PIXIE fits in to a huge range of Australian wall plates



SCAN ME



SCAN ME

Download the PIXIE and  
PIXIE PLUS Apps



## PIXIE Smart LED Strip Kits (white)

#FLP12VXM/XX/SBT



### Basic operation

- 1 click operate LED on/off
- To dim, long press and hold.
- 2 clicks go to maximum output

When paired with PIXIE SMFBTAS multifunction controller

### Applications

Residential dwellings for retrofit, renovation and new build; apartments; hotels and hospitality venues.

### Whats in the box

1 x White LED Strip, 1 x AC Adapter, 1 x BT Mesh module, 1 x IR Remote control, installation instructions

### Accessories

IR (Infra Red) remote control



SCAN ME

Download the PIXIE and PIXIE PLUS Apps



#FLP12VXM/XX/SBT

PIXIE Smart LED Strip Kits

See 2nd page for part number detail



PIXIE LED strip kits offer a plug and play LED strip dimming in 2 different versions of white in 2metre and 5metre kits. Comes with 24hour/7 Day scheduling, Groups, Scenes and mobile app control and configuration.

## Features

- Dimmable controlled by included remote, via SAL PIXIE or PIXIE PLUS apps or via PIXIE Multifunction controller (part#: SMFBTAS)
- 2 different versions of white - Warm White | Neutral Daylight
- 2m and 5m lengths available
- Dimming memory function, high performance, stable, even light output
- Pre wired for easy installation, plug-in & ready to use
- Cuttable every 50 mm, 2m or 5m kits, lumens shown are lm/m, strip power 6W/m.

## Electrical

LED Input/ AC Adaptor Input(V)(Hz)	12V / 240/50
Strip power	6W/m
Operating ambient min/max (°C)	0 to 40°
Typical wireless range	15 metres typical indoors ✱✱
IP Rating Strip	IP44
IP Rating AC Adaptor/ BT Mesh module	IP20

✱✱ Depending on building materials and construction.



## PIXIE Smart LED Strip Kits

#FLP12VXM/XX/SBT



### Related products

PIXIE Smart Dimmer  
#SDD300BTAM



PIXIE 600W Switch  
#SWL600BTAM



PIXIE Multifunction  
#SMFBTAS



PIXIE Smart GPO  
#SPO23BTAM



## Wiring Diagram

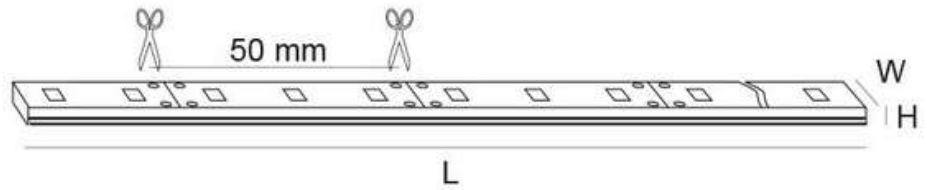

NOTE: when cutting LED strips, it is always important to calculate the remaining LED load to reconfirm its compatibility with the existing driver, as driver changes may be required with moderate reduction in loads.

Heatsink required for system performance

## Part Numbers

Model No.	Input Voltage (V/AC)	Beam Angle (°)	Dim (mm)	Watts per metre (W/m)	Colour Temp. (K)	LEDs Per Metre	CRI
FLP12V2M/WW/SBT	240	115	2000(L) x 8(W) x 2.5(H)	6	3000	60	80
FLP12V2M/NDL/SBT	240	115	2000(L) x 8(W) x 2.5(H)	6	5000	60	80
FLP12V5M/WW/SBT	240	115	5000(L) x 8(W) x 2.5(H)	6	3000	60	80
FLP12V5M/NDL/SBT	240	115	5000(L) x 8(W) x 2.5(H)	6	5000	60	80

## PIXIE fits in

PIXIE fits in to a huge range of Australian wall plates



SCAN ME



SCAN ME

Download the PIXIE and  
PIXIE PLUS Apps





## PIXIE Smart RGB LED Strip Kits

#FLP12VXM/RGBBT



### Basic operation

- Control intensity and colour from the PIXIE and PIXIE PLUS apps.

### Applications

Residential dwellings for retrofit, renovation and new build; apartments; hotels and hospitality venues.

### Whats in the box

1 x RGB LED Strip, 1 x AC Adapter, 1 x BT Mesh module, 1 x IR Remote control, installation instructions

### Accessories

IR (Infra Red) remote control



SCAN ME

Download the PIXIE and PIXIE PLUS Apps



#FLP12VXM/RGBBT

PIXIE Smart RGB LED Strip Kits  
See 2nd page for part number detail



PIXIE RGB LED strip kits offer a plug and play RGB LED strip with dimming in 2 different length versions - 2metre and 5metre kits. Comes with 24hour/7 Day scheduling, Groups, Scenes and mobile app control and configuration.

## Features

- High performance, stable, even light output, pre-wired for easy installation.
- Intensity (dimming) and colour controlled by included remote, via SAL PIXIE or PIXIE PLUS apps
- 2m and 5m lengths available
- Four different flashing modes with dimming memory function
- Cuttable every 100 mm

## Electrical

LED Input/ AC Adaptor Input(V)(Hz)	12V / 240/50
Strip power	6W/m
Operating ambient min/max (°C)	0 to 40°
Typical wireless range	15 metres typical indoors ✱✱
IP Rating Strip	IP44
IP Rating AC Adaptor/ BT Mesh module	IP20

✱✱ Depending on building materials and construction.



## PIXIE Smart RGB LED Strip Kits

#FLP12VXM/RGBBT



### Related products

PIXIE Smart Dimmer  
#SDD300BTAM



PIXIE 600W Switch  
#SWL600BTAM



PIXIE Multifunction  
#SMFBTAS



PIXIE Smart GPO  
#SPO23BTAM



## Wiring Diagram

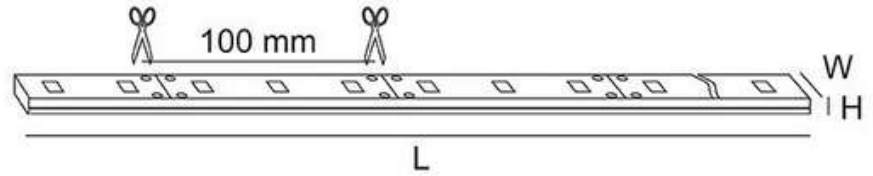

NOTE: when cutting LED strips, it is always important to calculate the remaining LED load to reconfirm its compatibility with the existing driver, as driver changes may be required with moderate reduction in loads.

Heatsink required for system performance

## Part Numbers

Model No.	Input Voltage (V/AC)	Beam Angle (°)	Dim (mm)	Dimmable	Watts per metre (W/m)	Colour Temp. (K)	LEDs Per Metre
FLP12V2M/RGBBT	240	115	2000(L) x 10(W) x 3(H)	YES	6	RGB	30
FLP12V5M/RGBBT	240	115	5000(L) x 10(W) x 3(H)	YES	6	RGB	30

## PIXIE fits in

PIXIE fits in to a huge range of Australian wall plates



SCAN ME



SCAN ME

Download the PIXIE and  
PIXIE PLUS Apps



Complete installation manual available at SAL National website.

PDF Prepared 1/12/2021 6:00am



© Copyright SAL - All Rights Reserved

## PIXIE Ambience

### ▶ Click Clack Snap

- Click on the Ambience switch-caps to the PIXIE smart module
- Clack the module into the Ambience wall-plate
- Snap on the Ambience face plate in your favourite colour from the selection

### ▶ Applications

Suitable for all Gen2 (G2) and Gen3 (G3) PIXIE smart modules

### ▶ Whats in the box

Wall plates come with mounting screws

Face plates come with the faceplate and matching buttons

### ▶ Accessories

PIXIE Ambience faceplates in White, Grey & Black in 1 to 6 gang configurations.



### PIXIE Ambience Wall plate and faceplate range



Ambience is a modern slimline wallplate and faceplate range with an understated beauty, colours to match any decor and the simplicity of PIXIE's Click Clack Snap approach to future proofing. It has been especially designed to work with the PIXIE smart home range of smart dimmers, switches and timer modules.

### Features

- Easy to install wall plates, with 1,2,3,4,5 or 6 gang configurations
- Stylish face plates to suit the various wall plate combinations, with a choice of white, black or grey colours, complete with a set of switch-caps.
- For flexibility wall plates are ordered separately to the face plates
- Durable polycarbonate construction, low profile design
- Wall plates are designed ever-so-slightly larger to fully cover the wall cavity better
- Insulated screw caps for combination flat/Philips head screws
- Compatible with all PIXIE G2 and G3 smart modules



SCAN ME



Download the PIXIE and  
PIXIE PLUS Apps



## PIXIE Ambience



### Related products

PIXIE Smart Dimmer  
#SDD300BTAM



PIXIE 600W Switch  
#SWL600BTAM



PIXIE Multifunction  
#SMFBTAS



PIXIE Touch Panel  
#STP54BTAS



## Ambience Range



Gloss White



Semi Gloss Gray



Semi Gloss Black

## Faceplate Options and Part Numbers

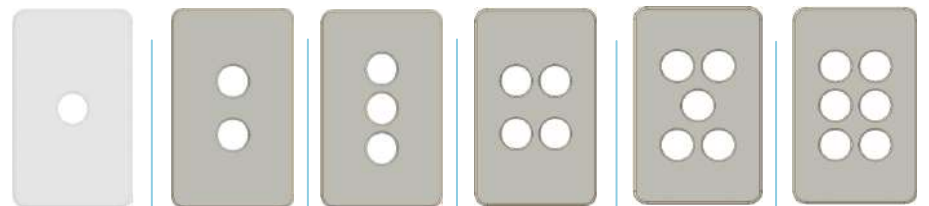

1 Gang + Buttons    2 Gang + Buttons    3 Gang + Buttons    4 Gang + Buttons    5 Gang + Buttons    6 Gang + Buttons

SWAC1GW	SWAC2GW	SWAC3GW	SWAC4GW	SWAC5GW	SWAC6GW
SWAC1SGB	SWAC2SGB	SWAC3SGB	SWAC4SGB	SWAC5SGB	SWAC6SGB
SWAC1SGG	SWAC2SGG	SWAC3SGG	SWAC4SGG	SWAC5SGG	SWAC6SGG

## Wallplate Options and Part Numbers

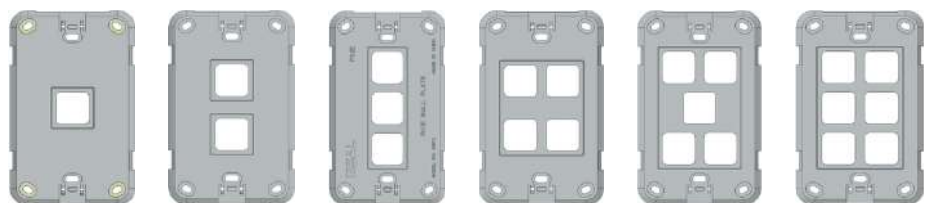

Wallplate only 1 Gang part#: SWP1    Wallplate only 2 Gang part#: SWP2    Wallplate only 3 Gang part#: SWP3    Wallplate only 4 Gang part#: SWP4    Wallplate only 5 Gang part#: SWP5    Wallplate only 6 Gang part#: SWP6

Wallplates compatible with PIXIE Ambience and Ambience XL faceplates



Download the PIXIE and  
PIXIE PLUS Apps

