

# PIXIE Smart Plug

#ESS105BT



## Basic operation

- 1 click to turn on/ off socket
- 4 clicks manual pairing
- 9 clicks reset device
- Long press the push button until LED indicator flashes to turn ON/OFF the USB output

## Applications

Energy management control of appliances in kitchens and bathrooms, phone chargers, wall and floor lamps

## Whats in the box

1 x Smart plug, installation instructions

## Accessories

None



SCAN ME

Download the PIXIE and  
PIXIE PLUS Apps



#ESS105BT  
PIXIE Smart Plug



A portable smart plug with a 1.5A USB port. Can be plugged into any standard Australian power outlet and control any appliances or lighting connected to the rated load capacity. Comes with Bluetooth Mesh Technology, Groups, Scenes, Schedules, Timers.

## Features

- DIY Plug and play device with full PIXIE smart functionality
- Control the smart plug via the standard push button action and PIXIE Apps
- Integral USB port, 5V DC, 1.5A
- Socket outlet and USB port can be separately scheduled and controlled
- Compliant to AS/NZS 3105:2014, AS/NZS 60950.1:2015

## Electrical

Power Supply	250V AC @ 50Hz
Max load resistive	1500W
Max load capacitive/ inductive	800W
Operating ambient min/max (°C)	0 to 40°
Typical wireless range	15 metres typical indoors **
IP Rating	IP20



# PIXIE Smart Plug

#ESS105BT



## Related products

PIXIE Smart GPO  
#SPO23BTAM



PIXIE Smart Switch  
#SWL350BT G2



PIXIE Smart Timer  
#STS350BT



PIXIE 600W Switch  
#SWL600BTAM



## Dimensions

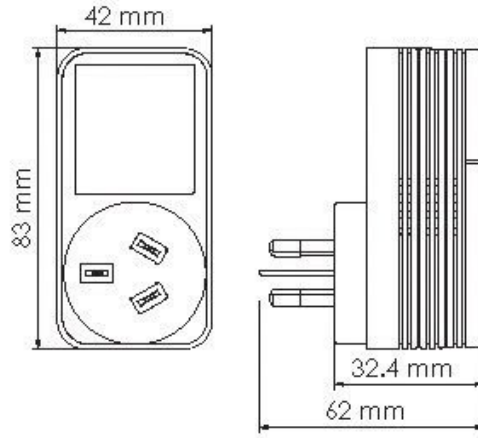

# PIXIE fits in

PIXIE fits in to a huge range of Australian wall plates



SCAN ME



SCAN ME

Download the PIXIE and  
PIXIE PLUS Apps

